

# KAB//Seating

## 100 Series

A black, high-back seat with a grid pattern on the backrest and a ribbed seat cushion. It is mounted on a multi-layered base with adjustment levers.

**KAB  
11/P1**

A large, high-back seat with a purple patterned fabric upholstery. The backrest has vertical ribbing. It is mounted on a multi-layered black base with adjustment levers.

**KAB AIR 15/P1**

ENTER THE COMFORT ZONE

[www.kabseating.com](http://www.kabseating.com)

# KAB//Seating

## 100 Series

**Air and Mechanical seating for vineyard and compact tractors**

Features	Air 15/P1	11/P1
Air suspension with a 12v integral compressor	●	
Air suspension with a 24v integral compressor	○	
Mechanical suspension		●
Vertical suspension stroke 80mm (3 1/4")	●	●
Integral height adjustment	0-30 or 70mm	70mm
Driver weight adjustment	50-120 (110-265lbs)	50-120 (110-265lbs)
Ride indicator	●	●
Suspension cover	●	●
Fore and aft adjustment 150mm (6")	●	●
Horizontal isolator*	○	
Seat belt widths 50mm (2")	○	○
Integral one piece foam and PVC trim	●	●
Rigid steel pan	●	●
Ventilation and surface drainage grooves	●	●
Drainage holes in base	●	●
Backrest extension	○	○
Fabric trim - Dino Moonstone	○	○
Variable up-stop	○	○

\*Available from November 2001

**Notes**

- Meets EEC 78/764 with amendments 83/190 and 88/468 Class I, II and III
- Meets flammability standards FMVSS 302 and ISO 3795 (<250mm/min)
- Seat belt anchorages to ISO 3776, ISO 6683 and SAE J386 with alternative sliderails.

- Standard
- Optional

Distributor

**England - KAB Seating Ltd**

Tel: +44 (0) 1604 790500 E.mail: marketing@kabseating.com  
www.kabseating.com

**Australia - KAB Seating Pty. Ltd**

Tel: +61 (0) 7 3275 7500 E.mail: enquiries@kabseating.com.au

**Belgium - KAB Seating SA**

Tel: +32 (0) 2 3661742 E.mail: info@kabseating.be

**France - KAB Seating**

Tel: +33 (0) 1 40 92 97 40 E.mail: info@kabseating.fr

**North America - KAB Seating**

Tel: +1 800 354 9621 E.mail: kabseating@nationalseating.com

**Sweden - KAB Seating AB**

Tel: +46 (0) 8 550 343 30 E.mail: office@kabseating.se

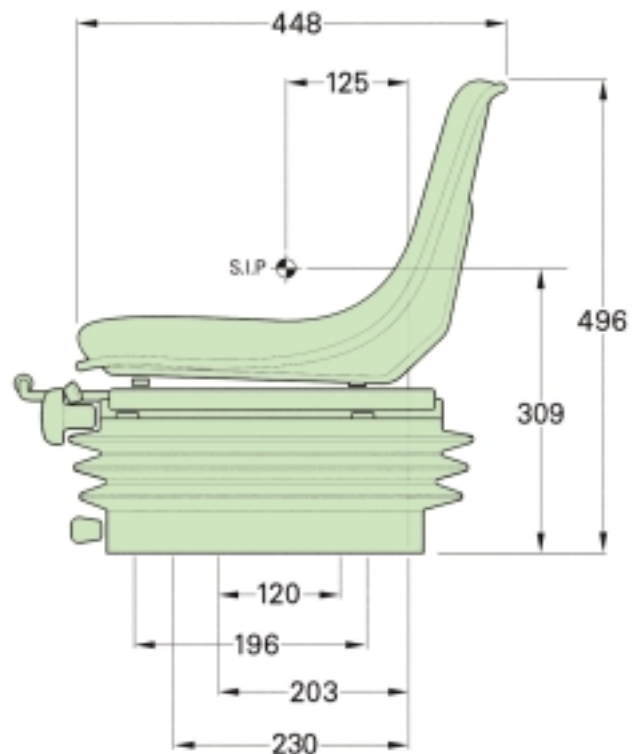
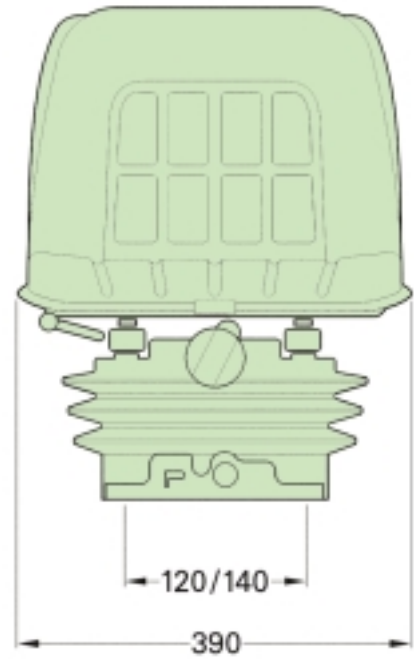

- SIP to ISO 5353.
- Dimensions at mid suspension stroke, middle height adjustment and at mid sliderail adjustment.
- Indicative dimensions
- 11/P1 shown

**These models are just part of the extensive 100 series range. Other suspension and seat combinations are available to suit larger vehicles.**

**For further details contact your local KAB office.**